

DEVELOPMENT AND MILESTONES OF ALTERNATING CURRENT HYDRAULIC DRIVES

TAMÁS FEKETE

*University of Miskolc, Department of Machine Tools
H-3515 Miskolc-Egyetemváros
tamas.fekete@uni-miskolc.hu
<https://orcid.org/0000-0002-2699-2621>*

Abstract: The energy transfer at the hydraulic drives can be solving with direct current hydraulic drives and alternating current hydraulic drives. At the direct current hydraulic drives, the operating fluid flow in one way besides the alternating current hydraulic drives, where it is alternating periodically between the hydrogenerator and the hydromotor. In this research, I would like to examine the evolution and milestones of this scientific field.

Keywords: *hydraulic system, hydraulic drive, milestone*

1. INTRODUCTION

Man has been preoccupied since ancient times to create the conditions for himself to make a living. Over time, based on the personal and ancestral experiences of his ancestors, he sought to develop the means necessary for his livelihood in all areas, thus saving the effort of human strength in order to achieve his goals.

The 20th century can be considered an era of scientific, technical, health and social development. We can also refer to it as the age of world wars, which also had innumerable consequences for posterity. The mechanization of production and services began in the 19th century, and the construction of global communications networks continued at an ever-accelerating pace in the 20th century. In this century, all areas of life have fundamentally changed and the whole of human society has changed considerably.

The development of hydraulic and pneumatic technology is due to this process. Hydraulic and pneumatic technology has undergone an explosive development in the 20th century because it has been essential for various industries to increase the level of technology in terms of productivity. The rapid mechanization and automation of production processes, the increasing complexity of the kinematic design of machines, and the need to increase transmitted power have placed increasing demands on energy transmission and control. Different energy transmitters can be used for the mode of energy transmission. The selection of the appropriate energy transmission technology is based on different criteria and should be compared with the specific characteristics of the energy transmission modes, which may limit their scope. The use of a liquid energy transfer medium, the simple change

of the characteristic parameters of the transmitted energy (force, torque), the simple protection against overload and the extremely high specific power make the hydraulic systems suitable for the fulfilment of highly and rapidly changing requirements.

After the Second World War, developments that were still secret at the time became more and more widespread in various fields of industry in addition to military technology. In the most developed countries of the world, companies manufacturing special elements have increasingly appeared and developed. Manufacturing plants specializing in a particular product type began to become more widespread, making it possible for suppliers to become large companies.

Due to the high-power density of hydraulics, there is a saying in the 20th century that:

'Hydraulics is the muscle of the 20th century; electronics is the brain.'

Towards the end of the 20th century, with the advent of increasingly modern mechatronic systems, computer control also came to the fore with the use of electrohydraulic components.

2. THE SPREAD OF HYDRAULIC TECHNOLOGY IN TECHNICAL PRACTICE

In the beginning, the hydraulic systems only used the energy of free-flowing fluid, and later, by increasing the pressure (with the help of mechanisms or increasing the temperature) and with the help of different mechanisms, they continuously developed over the millennia and thus hydraulic equipment was formed. In antiquity and the Middle Ages, the use of open-surface water energy dates back to early Mesopotamia, where B. C. VI. millennium, it was used in the field of irrigation and to ancient Egypt, where B. C. II. it has been used for water clocks for millennia. Other early examples of the use of hydropower are the qanat system in ancient Persia and the Turpan water system in ancient China.

In the Hellenistic period (B. C. 336–B. C. 30), the Greeks built highly developed water and hydraulic systems. One example of this is the Eupalinos aqueduct (Samos tunnel), which was the aqueduct channel of the city of Samos.

An early example of the use of the “hydraulic wheel” as a device for draining water is the Perachora wheel (B. C. III. century). This device is the earliest type of “water lifter” in Europe, which was used to transfer hydraulic media. It was driven by animal power, where the wheel equipped with containers for draining water was driven through two wheels with wooden teeth at right angles to each other.

Notable in the construction industry are the first hydraulic automaton of Ctesibius (Κτησίβιος) (B. C. 270) and the pump of the Egyptian Hellenic machinist and mathematician Heron (10–75). Héron writes of many devices that used hydraulic power, such as the “power pump” – known from many Roman sites – used to raise water in fire trucks. The volume change is caused by the piston moving in the cylinder, the direction of the liquid flow is controlled by self-acting valves. Due to their operating principle, the liquid delivery of piston pumps is not uniform.

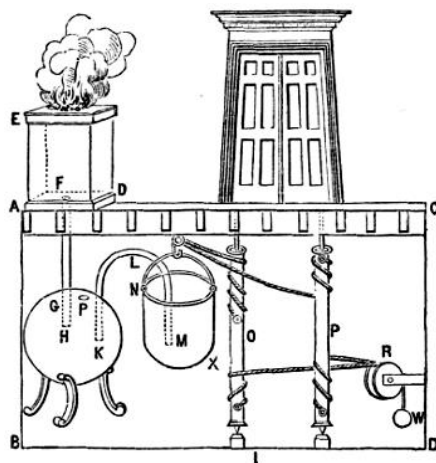

Figure 1. Automatically opening church door [7]

In ancient times, priests who possessed knowledge often used their knowledge manipulatively to strengthen faith. One striking example of this is the automatically opening church door. The altar, which opened the door automatically, was connected to a spherical tank approximately half filled with water. The shafts that operated the opening of the door wings, to which hinges were attached and reached all the way down to the floor of the basement under the church. Two chains were wound on the part of the shafts in the basement. A larger weight was attached to the end of one chain, which kept the doors closed, while the other chain was wound onto the shafts from the opposite direction, and a container was attached to its end, the mass of which, when empty, was less than the weight that kept the doors closed. The vessel was connected by a U-shaped pipe to the container placed under the altar. After igniting the fuel placed on the altar, the temperature increase caused the liquid in the tank to heat up. The heated air increased in volume, exerting pressure on the liquid in the tank. The fluid flowed through the U-shaped tube into the vessel due to the increased pressure, which caused it to descend and open the doors. The diagram of the church opening mechanism is shown in *Figure 1*.

In ancient Rome, a variety of hydraulic devices were developed, including public water supplies and numerous aqueducts. Water mills were also built to harness the energy of water. The water mill uses water energy as an energy source to drive the mill wheel. The main construction units of the water mill are: the mill wheel, the associated mechanical equipment, and the mill house itself, where grain is most often ground.

Hydraulic mining was used to extract gold in northern Spain. The Las Médulas alluvial gold mine was one of the largest of the mines. They worked with several long aqueducts and used the currents to wash away the soft sediment and then wash the ground of the valuable gold content.

One of the new representatives of hydraulics as a science was Blaise Pascal (1623–1662), who dealt extensively with the physics of liquids. He became known

in hydrostatics by creating the law later named after him. He contributed to the development of the natural sciences, designed a mechanical calculator, founded projective geometry, and developed the mathematical theory of probability calculation together with others. He formulated the physical law of moving vessels. At a very young age, he achieved results by examining the pressure conditions of gases and air pressure changes. His famous barometer experiment was actually a remote experiment, as it was carried out by his brother-in-law, P erier. In honour of his work, the pressure unit was named Pascal.

Daniel Bernoulli (1700–1782) was a doctor, mathematician and physicist born in Switzerland. One of his most important scientific results is the Bernoulli equation for stationary flows (he developed it for both compressible and incompressible media). Bernoulli’s law states that the sum of the different energies along a streamline in a flowing medium is constant. This law solved many of the physical issues that arose in shipping. His work, *Hydrodynamics*, is the first literature that discusses the mechanics of liquids with reference to a general principle with the help of analysis.

Many cities in England were so advanced that they used hydraulic networks in the 19th century. In the 20th century for handling machines, such as elevators, cranes, winches, and similar technical achievements.

Similar to other industrial sectors, the 20th century. At the beginning of the 20th century, Hungarian engineers recognized the potential of hydraulics and successfully used several hydraulic devices in metallurgical, mining, and other plants. As an interesting point, it can be mentioned that between the two world wars, the Budapest Opera House was the first in the world to use stage machinery operated with a hydraulic system. The stage machinery patented by the Asphaleia company, which operated with water hydraulics, was completed based on the design of set designer Josef Kautzky and Robert Gwinner.

The fire disaster at the Ringtheatre in Vienna played a role in the spread of hydraulic technology. He drew attention to the fact that theatres need to be improved from a fire protection point of view. With the help of the hydraulic stage machinery, the set and stage fields were moved by hydraulic cylinders instead of manual force. The stage machinery of the Budapest Opera House also included the hydraulic movement of the circular horizon curtain and the two hydraulic freight elevators, which were also the first in the world to be used in Hungary.

In the middle of the 20th century, Hungarian engineers only rarely had access to specialized literature in which they could learn about new technical results. Due to weak foreign trade, elements were made primarily for domestic machine tool production based on the new technical information. When international relations took off, the Hungarian pneumatics and hydraulics industry was formed at the same time. Modern machines have arrived in our country in increasing numbers, so the demand for specialists who understand this has increased. As a result, pneumatics and hydraulics education was introduced in secondary and higher education from the 1970’s.

The education and spread of the theory of hydraulics resulted in the strong development of the industry. As a result, engineers and researchers increasingly

came to the introduction of alternating current hydraulic systems. The appearance of alternating current hydraulic drives in written form in the 20th century can be dated to the first quarter of the century.

3. ALTERNATING CURRENT HYDRAULICS IN TECHNICAL PRACTICE

The first publication that can still be found today is attributed to the Romanian researcher George (or Gogu, known by both names) Constantinescu, whose results could already be used for practical implementations. Constantinescu was primarily involved in the design and testing of devices operated with alternating current fluids. In 1910, he emigrated to London, where he was able to focus more on his studies. The single-phase rock drill was able to drill through a hard block of granite quietly and evenly. With the help of this prototype, he illustrated the power of the alternating current system. In Constantinescu's propeller, the generator rotated at high speed, while the propeller (engine) rotated at low speed. A photo of his experimental equipment is shown in *Figure 2* [8].

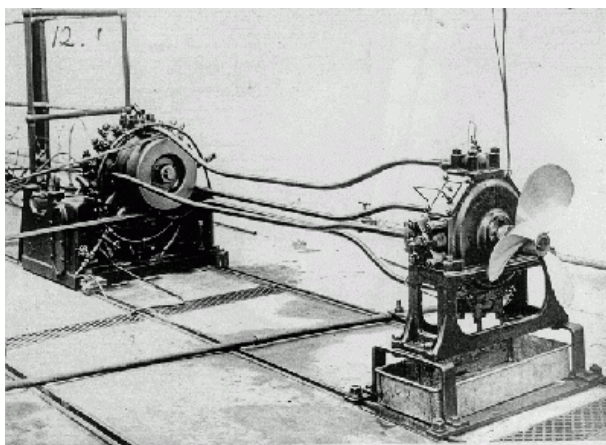

Figure 2. George Constantinescu's four-phase experimental device for marine use and the structural design of the generator [8]

With Constantinescu's alternating current devices, the stroke of the phase pistons in each phase could not be modified, i.e., only the drive frequency (generator speed) could be modified. His equipment could have been used on a wider scale if he had also used amplitude control (the possibility of changing the piston stroke).

Bergeron L. (1911–2001) during the graphic analysis of pressure waves examined a water extraction device, which operated the water extraction piston pump by alternating movement of two liquid columns.

In the 1970's, we can find works published by Hibi, A., Prokes, J. and Prikryl, I. on the topic of alternating current hydraulic systems. A. Hibi, a professor at the University of Shizuoka, published the construction of an asynchronous alternating current hydraulic drive (a two-phase system operated with a fixed-stroke generator)

and its test results. Prokes, J. dealt with the grouping of alternating current hydraulic mechanisms based on electrical analogy. He found that the grouping can be done according to the size of their frequency or the types of connection of the resistors. Prikryl, I. established that the so-called hybrid mechanism (Prokes: it can be operated with either direct or alternating current) can be used, for example, as a transformer or even as a current controller. W. M. J. Schlösser, a professor at the University of Eindhoven, deals with synchronous AC hydraulic drives in his work.

In Hungary, synchronous and asynchronous AC hydraulic drives began to be researched in the 1970's at the University of Miskolc.

In the beginning, alternating current hydraulic energy transmission was used as a vibration generating device in the dynamic testing of machine tools. Using the electrical analogy, János Lukács classified alternating current hydraulic drives. He divided AC hydraulic drives into two larger groups: synchronous and asynchronous systems. He examined the typical properties of hydraulic energy transmission and determined the hydraulic power for all types of resistance. From his experiments, he concluded that from a practical point of view, two and three phases and their integer multiples can be used. He performed both no-load and load tests on his two-phase experimental equipment. He determined the movement and flow conditions of synchronous and asynchronous AC hydraulic drives. Later, various alternating current hydraulic drives were implemented, for which a patent was also issued. One of the patented versions of the alternating current hydraulic drive is shown in *Figure 3*. The alternating movement of the phase piston of the alternating current hydromotor is converted into alternating rotary movement by a mechanical rectifier, or otherwise known as a freewheel [8].

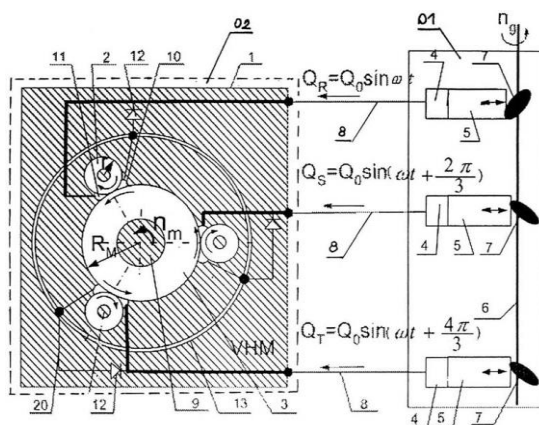

Figure 3. Diagram of an alternating current hydraulic drive patented by János Lukács [8]

Breznai, A. dealt with dynamic tests of synchronous hydraulic drives and their simulation at a theoretical level but did not prepare experimental equipment and practical measurements in this regard, which would have verified the effectiveness of the calculations.

Dr. Raid Ahmed Smadi designed an alternating current hydraulic clutch and examined its operating principle from a theoretical point of view. performed measurements on it both at idle and under load.

Table 1
Milestones in the research of alternating current hydraulic drives [9]

Year of Publication	Author	Milestones	Country
1913	Constantinescu, G.	mechanisms operating with alternating currents of fluids	England
1950	Bergeron, L.	pressure waves generated in alternating system hydraulic systems	France
1969	Prokes, J.	testing of alternating current hydraulic synchronous drives	Czech Republic
1975	Prikryl, I.	testing of alternating current hydraulic synchronous drives	Czech Republic
1970	Lukács, J.	examination of synchronous and asynchronous alternating current hydraulic drives	Hungary
1979	Hibi, A.	investigation of a three-phase AC hydraulic synchronous drive	Japan

During his research, dr. Imre Czupy examined asynchronous hydraulic drives. He used the experimental, alternating current linear vibrating equipment, which was also operated under industrial conditions, to remove the stumps left after forestry logging. He determined the relationships between the vertical billet lifting force and the diameter of the billet cutting blade, the laws of billet vibration, and analysed the energy of the vibrating system, respectively. performance conditions. Research in the direction of sperm separation has not yet been fully completed.

Dr. János Erdélyi dealt with the design and construction issues of an asynchronous alternating current hydraulic drive. During his research work, an experimental device was constructed. He examined the power and motion transmission properties of this equipment. He proved that in the case of rigid and hydrodynamically short phase lines, the pressure waves generated in the phase lines do not create dangerous pressure peaks. With the help of the correlations, he showed that the relationship between the pressure and the flow rate of the phase fluid flow of the alternating current asynchronous hydraulic drive can be examined as a concentrated parameter. He also studied the methods of balancing actuating eccentric disks. There was no investigation of the pressure waves or on the extent and possible effects of the temperature increase that may arise from the pulsating movement of the energy transmitting medium. *Table 1* shows the milestones in the research of alternating current hydraulic drives.

REFERENCES

- [1] Erdélyi, J. et al. (2008). A kontrakciós henger konstrukciós és működési tulajdonságai. *Pneumatika, hidraulika, hajtástechnika, automatizálás*, Vol. 12, Nr. 1.
- [2] Erdélyi, J. (2006). Váltakozó áramú hidraulikus aszinkron (A-VAH) hajtás. *OGÉT 2006. XIV. Nemzetközi Gépész Találkozó*, 2006. április 27–30., Marosvásárhely.
- [3] Fekete, T. (2014). The alternating current synchronous hydraulic drive. *ANNALS of Faculty Engineering Hunedoara – International Journal of Engineering*, Vol. 12, Nr. 2, 235–238.
- [4] Fekete, T. (2017). Alternating current hydraulic drive the possibility of applying. In: Jármái, K., Bolló, B. (eds.). *Vehicle and Automotive Engineering, Lecture Notes in Mechanical Engineering*. Springer, Cham.
https://doi.org/10.1007/978-3-319-51189-4_5
- [5] Fekete, T. (2011). Háromfázisú váltakozó áramú hidromotor forgóelemes fázistér kialakítással. *XXV. microCAD International Scientific Conference*, Miskolci Egyetem, 2011. március 31. – április 1.
- [6] Fekete, T. (2013). Szinkron rendszerű váltakozó áramú hidraulikus hajtás. *OGÉT 2013. XXI. Nemzetközi Gépész Találkozó*, 2013. április 25–28., Arad.
- [7] Andai, P. (1965). *A technika fejlődése az őskortól az atomkor küszöbéig*. Akadémiai Kiadó, Budapest.
- [8] Petrescu, R. V. V. et al. (2017). George (Gogu) Constantinescu. *American Journal of Engineering and Applied Sciences*, Vol. 10, No. 4.
<https://doi.org/10.3844/ajeassp.2017.965.979>
- [9] Lukács, J. (2005). *Váltakozó áramú hidraulikus hajtás motoregysége forgóelemes fázisterekkel*. Használati mintaoltalom, lajstromszám: 3148.
- [10] Fekete, T. (2022). *Váltakozó áramú hidraulikus hajtás kapacitás változása rugalmas fázisvezetékek alkalmazása esetén*. Disszertáció, Miskolci Egyetem.