

DESIGN OF A FORCE MEASURING UNIT FOR ROBOTIC APPLICATIONS

LÁSZLÓ RÓNAI

*University of Miskolc, Institute of Machine Tools and Mechatronics
H-3515 Miskolc-Egyetemváros
ronai.laszlo@uni-miskolc.hu
<https://orcid.org/0000-0002-1717-1493>*

Abstract: The paper deals with design process of a force measuring unit, which is capable to mount onto a robot or to integrate into a measuring device. The main element is a beam type load cell equipped with strain gauges in Wheatstone bridge configuration. In order to measure the force only in one direction a linear guide rail is used to lock the degrees of freedom. The unit will have a microcontroller board to process and transfer the data to a personal computer. Furthermore, the system will be capable to intervene processes thanks to the digital inputs and outputs of the electric board. The paper introduces the 3D model of the device, and its components.

Keywords: *load cell, linear guide rail, force measurement*

1. INTRODUCTION

Nowadays measuring and data acquisition is an important tool to investigate a phenomenon of a process or make sure of the correctness of operations, e.g., at industrial environment. Force measurement is required in many fields, e.g., hydraulics, pneumatics, robotics etc.

In robotics there are commercially available force and torque sensors, which can give feedback on the forces during the process [1], but they are expensive and most of them cannot ensure flexible programming capability to make the robot intelligent. Several publications deal with the development of special purpose robotic end-effectors, which consist of force sensors to measure the force of a specific process. In [2] a self-developed end-effector containing flexible element equipped with strain gauges is developed, which is suitable for polishing process performing with industrial robot. The unit includes a 6-axis force/torque sensor. A low cost 6 axis capacitor-based force sensor is developed in [3], which can be suitable for robotic applications especially at human-robot interactions.

Not only for industrial robotics, but also for other fields, force measuring can be necessary, e.g., in [4] a self-devised low cost, modular 3 degree of freedom (DOF) force sensing unit is investigated, which serves wrist rehabilitation purposes. The authors used beam type load cells equipped with HX711 Analog/Digital converter unit.

The main aim of this paper is to develop a force measuring unit, which can be integrated into a robotic cell or a special purpose testing device. Previously another version of the unit was designed and manufactured, which was mounted onto an industrial robot to serve force measurements during assembling tasks [5]. The unit had two thin sheet metals [6] to prevent the unwanted force components. The new device will have linear guide rail instead of sheet metals.

The remainder of this paper is organized as follows. Section 2 introduces the sketch of the planned force measuring unit with its main elements. Furthermore, the necessary requirements of the measurement unit are also detailed in this Section. The 3D model of the device is introduced in Section 3. The concluding remarks and the plans for the future are given in the last Section.

2. REQUIREMENTS AND SCHEMATIC PRESENTATION OF THE UNIT

The main goal is to develop a force measurement unit, which can be used in robotics and other fields. The system would be capable to intervene in processes depending on the measuring task. Therefore, an ATmega328 based microcontroller (μC) is placed to provide the decision capability of the system. An HX711 24-bit resolution analogue-digital (A/D) module is integrated to transform the bridge voltage of the load cell to digital data.

Necessary hardware and software demands of the measuring system can be formulated, which are the following:

- Overload protection needs to be solved.
- Provide an opportunity to save the measured force values for post processing.
- The system must be reprogrammable depending on the measurement task to be performed.
- Existence of intervention in processes.
- The structure should be compact and lightweight.
- Assembling and disassembling should be not complicated.
- Provide a 1-way force measurement.

A robotic intelligent end-effector, which is capable to use it during assembling tasks was previously developed [7] and it was used with an industrial robot to perform an intelligent assembling operation [5].

The system to be developed contains the same aluminium alloy beam type load cell, which has 200 N capacity. The data of the load cell can be seen in Table 1. The main difference between the previously developed and current device is the elimination technique of the unwanted force components. The current system will use a linear guide rail unit to lock the DOF. The type of the unit is a MGN12H 12 mm with a linear carriage. The scheme of the system can be seen in *Figure 1*.

A pneumatically actuated Gimatic GS25 gripper will be mounted to make the availability of grasping.

Table 1
Specification of the load cell

	Value
Dimensions (LxWxH)	80 mm × 12.7 mm × 12.7 mm
Capacity	200 N
Safe overload	~240 N
Hysteresis	0.03 %
Excitation voltage	5 V
Number of strain gauges	4
Range of the operating temperature	-20 °C–65 °C

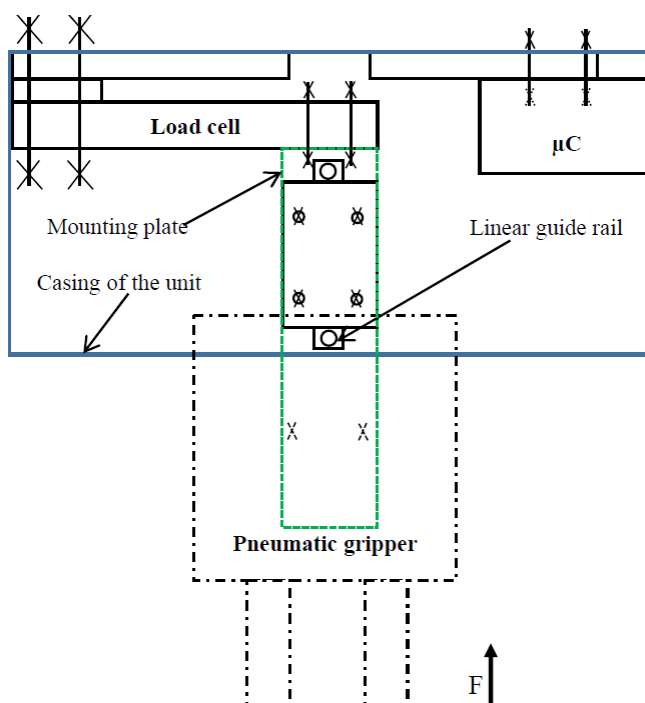

Figure 1. Scheme of the measuring unit

3. DESIGN PROCESS OF THE UNIT

The modelling of the system is performed in the Autodesk Inventor Professional 2018 software. The 3D model of the system is shown in *Figure 2* and *Figure 3*, respectively. The main elements of the unit according to *Figure 2* and *Figure 3* are the following: 1) Mounting plate; 2) Load transferring elements; 3) Electronics board; 4) Pneumatic gripper; 5) Connection element; 6) Load cell; 7) Overload protection; 8) Linear guide rail with the carriage.

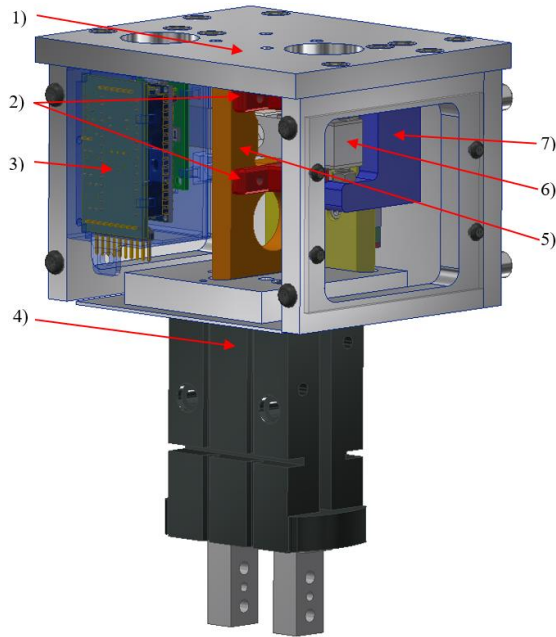

Figure 2. The 3D model of the system 1

The electronics of the system consists of an ATmega328 microcontroller-based Arduino Nano development platform, the HX711 A/D converter, and a special purpose board, which contains optocoupler units for voltage levelling. The electronics of the unit will get a self-devised 3D printed casing. The overload protection is ensured by a horseshoe shaped element, which was introduced in the previous system [7]. It has set screws to adjust the limit force of the load cell.

A connection element is necessary in order to join the gripper with the carriage and to design the connections of the load transferring elements, and the overload protection element.

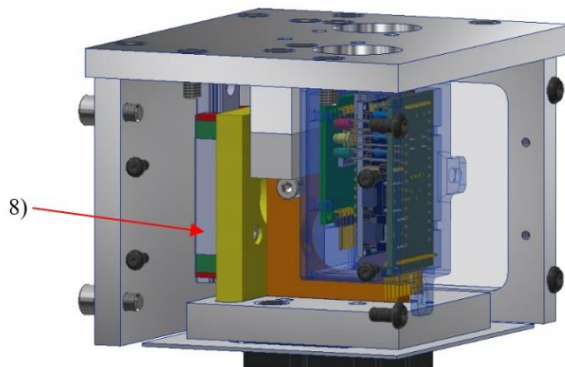

Figure 3. The 3D model of the system 2

The drawing of the connection element with the dimensions can be seen in *Figure 4*. The element will be manufactured from aluminium. In order to fulfil the requirements of the measuring unit, weight reduction is performed. Bores are placed to connect the load transferring elements and to mount the connection element to the carriage with the gripper and its mounting plate.

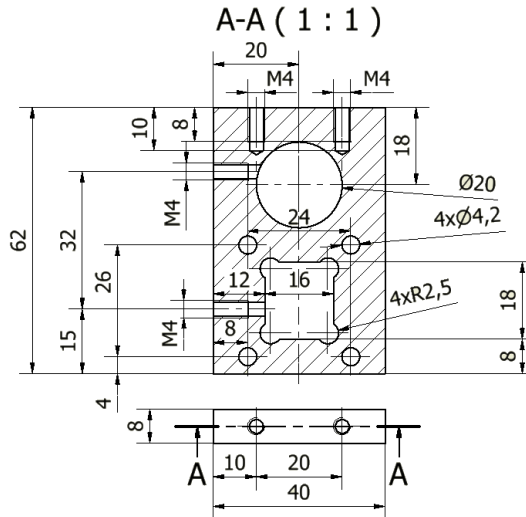

Figure 4. Technical drawing of the connection element

The load cell will contain two steel plates (see *Figure 5*), which prevent the set screws of the overload protection element and the set screws on the load transfer element from being pushed into the aluminium beam. The ends of the set screws of the load transfer element will be machined to cone.

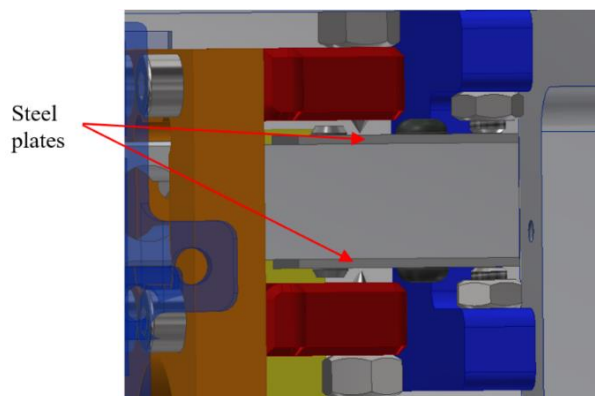

Figure 5. Load transferring elements and the overload protection

Since the load cell has 0.1063 mm elastic deflection at 200 N load [6], precise adjustment of the screws is essential.

4. SUMMARY

A force measuring unit was designed, which is capable to use in robotic applications or in test systems to perform force measurements. The 3D model was created in Autodesk Inventor Professional software. In addition to force measurements, the unit will also be suitable for intervention since the electronics panel includes both digital outputs and inputs with optocouplers.

In the future the system will be manufactured and integrated to a Rexroth compact module in order to perform force measurements.

REFERENCES

- [1] Loske, J. – Biesenbach, R. (2014). Force-torque sensor integration in industrial robot control. *15th International Workshop on Research and Education in Mechatronics (REM)*, <http://doi.org/10.1109/REM.2014.6920241>.
- [2] Ren, C. et al. (2016). Theoretical analysis of a six-axis force/torque sensor with overload protection for polishing robot. *23rd International Conference on Mechatronics and Machine Vision in Practice (M2VIP)*. <http://doi.org/10.1109/M2VIP.2016.7827338>
- [3] He, Z.; Liu, T. (2021). Design of a three-dimensional capacitor-based six-axis force sensor for human-robot interaction. *Sensors and Actuators A: Physical*, Vol. 331, Article ID 112939, <http://doi.org/10.1016/j.sna.2021.112939>.
- [4] Mayetin, U. – Kucuk, S. (2021). A low cost 3-DOF force sensing unit design for wrist rehabilitation robots. *Mechatronics*, Vol. 78, Article ID 102623. <http://doi.org/10.1016/j.mechatronics.2021.102623>
- [5] Rónai, L. – Szabó, T. (2020). Modeling and Robotic Handling of a Snap-Fitting Box Buckle. *Pollack Periodica*, Vol. 15, No. 2. <http://doi.org/10.1556/606.2020.15.2.9>
- [6] Rónai, L. (2018). Design Aspects of a Robotic End-effector. *Design of Machines and Structures*, Vol. 8, No. 2, pp. 52–58.
- [7] Rónai, L. – Szabó, T. (2019). Intelligens robotmegfogó fejlesztése. *Multi-diszciplináris Tudományok*, Vol. 9, No. 4. <https://doi.org/10.35925/j.multi.2019.4.40>