

## **THE METHODS OF NUMERICAL MECHANICS FOR THE IMPROVEMENT OF MACHINE-TOOLS**

ATTILA SZILÁGYI – DÁNIEL KISS

University of Miskolc, Department of Machine Tools  
3515 Miskolc-Egyetemváros  
*szilagyi.attila@uni-miskolc.hu, daniel.kiss@uni-miskolc.hu*

**Abstract:** This paper gives a brief summary on the mechanical and thermal applicability of the finite element method (FEM) from the field of designing procedure of machine tools. The solutions of certain problems, as examples, are also demonstrated. First the summary of such phenomena is performed, where the application of numerical methods is inevitable. Through the brief summary of the general problem of elasticity, the justification of the numerical methods is demonstrated. Finally, examples are set to demonstrate the applicability of the numerical methods and the achieved results, which demonstrate the efficiency of the FEM applied for the development of machine tools. Among several numerical methods the FEM is focused on in this paper.

**Keywords:** *Machine-tools, numerical, mechanical, thermal, FEM*

### **1. INTRODUCTION**

During the operation of any type of manufacturing device or machine-tools, several incidents should be taken into consideration from the fields of kinematics, dynamics, structural or thermal analysis which may influence the accuracy of the manufacturing process considerably. The influence of these factors already in the preliminary design-phase of the device, or during the operation of an existing machine needs to be considered. The preliminary judgement of such incidents can be conducted only in theoretical ways, by the means of the numerical methods of mechanics. The theoretical conclusions can be validated and completed by an experimental investigation of a similar device.

The mathematical description of such phenomena generally requires of setting up very complicated nonlinear ordinary or partial differential equations or equation-system. Due to the complicated boundary conditions coming from the geometry, the establishment of the exact, closed-form solutions of such governing equations may be blocked by impassable barriers and excludes the application of pure and exact analytical procedures. In order to overcome these theoretical difficulties, the application and the improvement of numerical methods have needed to be implemented. Due to capability of providing an excellent approximation, the finite element method (FEM) is assumed to be the most frequently applied numerical method.

Our paper, through the analysis of some simple cases, demonstrates the applicability and diversity of the FEM on the field of the design procedure of manufacturing devices and machine-tools. First of all, the need for the modelling procedure is mentioned in the followings, then the phenomena which require being modelled on the field of the machine-tools is summarized in the following chapter.

## **2. PHENOMENA ONE MAY ENCOUNTER WITH DURING THE OPERATION OF MACHINE-TOOLS**

The phenomena may arise during the operation of a machine tool or a manufacturing device, and which may interact with each other yielding a significant negative influence on the accuracy of the manufacturing process, can be sorted into three fundamental groups of Physics: kinematics, mechanics and thermodynamics.

Among the phenomena from the field of kinematics, the errors from the geometrical uncertainties, the deviations from the ideal geometrical entities can be mentioned, such as the straightness error, the perpendicularity deviation, spherical deviation, or the eccentricity etc. Since the detection of such defects can be performed only at an existing device, hence the preliminary judgement of these properties can be done only during the design process of the device by the tolerance-calculations. We note, that the modern engineering iCAD softwares enable to conduct such calculations which, however, are not considered to belong to the group of the “classic” simulations, hence the phenomena from the field of kinematics are not focused on in this paper. The inertial forces and loads due to a motion analysis can also be considered as phenomena from the field of kinematics, however these problems would rather be investigated in connection with some dynamical points of view as a link to the structural or fracture mechanics of different structures.

Among the mechanical phenomena those ones can be mentioned which are in connection with the loadings induced by the operation of a machine, such as the contact stresses and stress concentration. Another group of phenomena from the field of mechanics are related with the deformation of the structure, such as the deformation of the rolling elements, guidelines and guideways, or the main spindle, and which may yield the plastic deformation of certain concentrated zones of the device. The fluid-dynamical (coolants and lubricants) and tribological (slideways, the stick-slip, aerostatic guides), as well as the problems of the lubrication-theory (hydrostatic and hydrodynamic guideways) can also be mentioned among the mechanical phenomena. The phenomena from the field of dynamics [6–7] can also be included by a large set within the mechanical ones, such as the inertial forces and moments which may induce the different types of vibrations (free, forced, self-excited and parametrically forced vibrations) that – in extreme cases – may contribute to the appearance of the phenomena from the field of fatigue and fracture mechanics. Among the vibrations, the strongly nonlinear transversal vibrations of the belts [3], the linear torsional vibrations of the main and sub spindles [2], and the strongly stochastic vibrations coming from the manufacturing process can be mentioned. The wide variety of the contact stress phenomena is worth mentioning separately, since the load-flow

spreading all along the machine-structure is composed of the contact stresses induced by the connecting machine elements, hence, the consideration of these forces, while the Saint-Venant-principle is also taken into account, is vital for creating a well approximating mechanical model for the numerical simulations. As still regarding the contact loadings, all the above-mentioned phenomena are induced or at least influenced by their contact forces.

Among the phenomena from the field of Thermodynamics, the influences from the heat sources of the machine can be mentioned, as well as the different types of the heatpropagation can also be focused on, let alone the temperature field and the heatdeformations and stresses yielded by the heatpropagation. The different types of the heat-transport processes belong also into this group, which may rise during the analysis of the coolants and lubricants. As regards the investigation of the thermodynamical phenomena, depending on being transient or stationary, may require a lot more complicated model and computational capacity, than that of the pure mechanical ones [4].

Some other types of phenomena can also be mentioned. These types cannot be classified as above, but may induce mechanical or thermodynamical phenomena during the operation of a machine. The electromagnetic phenomena coming from a linear-motor system can be sorted into this group. Beyond the electromagnetic influences, the so-called parasite-force, which is a concomitant phenomenon of a plane linear motor drive can be mentioned, that may influence the operation of a sliding guide by directing the guideways to extremely high friction forces. The nonlinear electrical phenomena of a control-system of a CNC-drive system can also be mentioned, that may take a drawing-back effect on the accuracy of the positioning. A specific optical phenomenon may rise during the operation of a special, ultraprecise manufacturing device operated by LASER. In this case the LASER beam with relatively long coherence length is applied for hologram printing. Since the LASER beams are flying in outer space this time, then the index of refraction of the air is vital to be stationary and constant, which can be achieved a properly designed cooling system.

It is well known, that the phenomena mentioned above might show up as the interaction of single ones, in other words the phenomena can be coupled by influencing each others' effects, which, in extreme cases, may yield the amplification of the single ones. As an example, a less stiff rotating shaft can be mentioned, which rotates an unbalanced heavy mass yielding large deformations and displacements that may induce the nonlinear unstable, parametrically excited vibration of the shaft. Another instance for the interaction of single phenomena may come from the fields of thermodynamics and the structural analysis, where the interaction of the mechanical and thermal deformations may have a negative influence on the accuracy of the manufacturing process. As a remark, we note, that the phenomena mentioned above – except the optical one – may show up at the same time within a modern motorspindle system, hence the theoretical analysis of such a device – mainly during the design phase – may have a serious challenge for the design engineers.

The experimental investigation of the phenomena mentioned above is detailed by the reference [1].

### 3. THE NEED FOR THE NUMERICAL COMPUTATIONS

Due to the complicated kinematical and dynamical boundary conditions, the analytical investigation of the above-mentioned phenomena, even if the physical law is assumed to be linear, may be blocked by impassable barriers. As an example, see figure below which depicts the fundamental problem of the strength analysis based on the theory of elasticity (*Figure 1*).

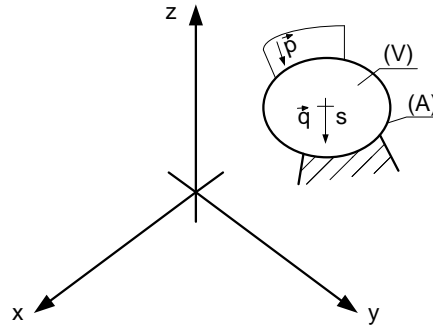

**Figure 1**  
*The fundamental problem of the strength analysis*

The solution procedure of such problem is focusing on the establishment of the stress, deformation and the displacement fields of the elastic body subjected to a certain loading. The analytical investigation of this problem can be set up as follows [5].

Let  $\vec{u}(\vec{r}) = u\vec{e}_x + v\vec{e}_y + w\vec{e}_z$  be denoted to the unknown displacement field, while the  $\underline{\underline{A}} = \underline{\underline{A}}(\vec{r})$ , and  $\underline{\underline{T}} = \underline{\underline{T}}(\vec{r})$  tensor-quantities stand for the unknown deformation and stress fields as the functions of the  $x, y, z$  coordinates. As regards the symmetry of the tensors,  $3+6+6=15$  pieces of field-quantities need to be established by the following equations. First of all, the

$$\underline{\underline{A}} = \frac{1}{2}(u \circ \nabla + \nabla \circ u) \quad (1)$$

geometrical equation, then the

$$\underline{\underline{T}} \cdot \nabla + \vec{q} = \vec{0} \quad (2)$$

equilibrium equation and, finally the

$$\underline{\underline{T}} = \underline{\underline{D}} \cdot \underline{\underline{A}} \quad (3)$$

law-of-material equation can be set up. The simplest case for (3) is the Hook'-law. Besides the *Equations (1)–(3)*, the  $\vec{u} = \vec{u}_0$  ( $\vec{r} \in A_u$ ) kinematical and the  $\underline{T} \cdot \vec{n} = \vec{p}$  ( $\vec{r} \in A_p$ ) dynamical boundary conditions are also available, where  $A_u \cup A_p = A$ .

At complicated geometrical entities and shapes, such as the welded or cast machine beds, stepped main spindles, subspindle-drives with rolling element bearings etc., the pure analytical investigations, even if they are based on linear partial differential equation-system, cannot be conducted by yielding exact, closed-form solutions. Still there is a strong demand from the side of the engineers for solving these rather complicated problems, even with the application of certain approximation methods, the special numerical methods of mechanics, by which an approximating solution of arbitrary accuracy can be obtained and the (1)–(3) problem can be investigated at arbitrary boundary conditions. There are several numbers of such softwares are available for the mechanical engineers. Generally, these softwares are the integrated parts of a wider engineering software package, such as the CAD-packages. The most frequently applied numerical mechanical method on the field of the mechanical engineering is the finite element method (FEM). The typical features and the applicability of an FEM-software through the analysis of some examples from the field of machine-tools are detailed in the following chapters.

#### 4. THE NEED FOR THE NUMERICAL COMPUTATIONS

Unlike some other numerical procedures, such as the method of differences, the collocation method, the FEM will not yield the direct numerical solution of the original partial differential equation-system, but, bypassing this step, yields such solutions which are based on some variational principles. The detailed theoretical backgrounds can be found in [5]. The FEM, in any case, assumes an appropriately created geometrical model, which, due to the modern integrated engineering softwares, generally is called the digital prototype of the machine (*Figure 2*).

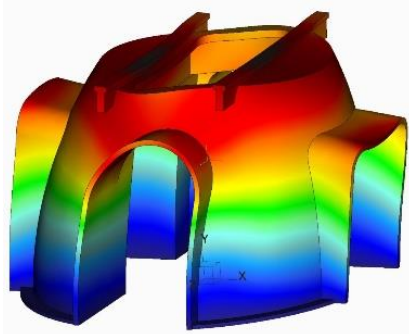

**Figure 2**

*The digital prototype of the machine structure used for the FEM*

The figure depicts a dome-shape machine structure of grey cast-iron. This structure is the central part of a large milling-drilling machining centre, which is being developed within the frames of a tender called the GINOP-2.2.1-15-2017-00093 project titled *The Development of Ultraprecise and Freedom Type Machining Centers*. Since this central part contributes to the novelty of the machine, several mechanical and thermal properties of this part needed to be investigated, then, in accordance with the preliminary concepts, the design and the geometrical shape of the structure had to be finalized. During the design and improving process, several number of structural and dynamical properties, which sometimes are interacting with each other, had to be investigated, and had to be taken into consideration in order to achieve an optimized geometrical structure.

Since an ultraprecise drilling-milling machining centre is investigated, the static stiffness of the central part of the entire machine is assumed to be the most important feature, which is the response to the static loading. The static stiffness of the machine structure is vital during a milling manufacturing process, since the mean value of the time-varying feeding-force component, which is superimposed by the periodic time-varying component, is not zero, hence the accuracy of the manufacturing process might strongly be influenced by the unsatisfactory stiffness. Similarly, also the dynamic stiffness of the construction is of utmost significance, since it is the interpretation of the response of the system to a time-varying – generally to a harmonic – forcing term, and can be expressed as the displacement amplitude considered along a particular direction. In extreme cases it might refer even to the resonance. It is always a 3D-environment modal analysis with a linear material law is conducted prior to the simulation of the dynamic stiffness of a structure, since it enables us to establish the arbitrary number of natural frequencies and the concomitant mode-shapes of the investigated structure in order to compute the necessary response features. The main objective of our investigation in this case was to design and create an optimized geometrical shape having as high first natural frequency as possible, since, this way, the higher order natural frequencies would be increased and shifted from the manufacturing frequency range yielding a reduced possibility for the resonance during manufacturing. The figure below depicts the mode shape belong to the first natural (*Figure 3*).



**Figure 3**  
*The 1<sup>st</sup> mode shape of the structure*

Several other dynamical simulations with different damping coefficients have been conducted by the 3D model seen on *Figure 3*, such as the modal analysis mentioned above, then the subsequent analysis for establishing the quantities of the dynamical stiffness, then the one for establishing the response functions to the harmonic and impact forcing terms and, finally, the one for setting up the optimized geometry. As regards the static structural investigations, the quantities of the static stiffness have been computed, as well as the contact stresses, while prestressed loading also was assumed. Among others the surfaces of guides subjected to pressure have also been checked as well as several numbers of global sensitivity analysis were also conducted in order to create the final optimized geometrical shape of the structure. It is clearly seen, that due to the extremely complicated kinematical boundary conditions, these investigations cannot be conducted without applying the means of the numerical computational methods. The chart below depicts the state of resonance by displaying the time-history of the displacement response function at a special point of the construction (*Figure 4*). The influence of the damping of different raw materials were investigated by such charts.

Besides the dynamical simulations, several other structural (static) computations have also been conducted. As it has been mentioned above, the part seen on *Figure 2*, is the central structure of the entire machine and presents several novelties. Consequently, the investigation of all the quantities referring to the static stiffness has been performed, since the estimated total weight of the structure is roughly 60 tons, and at installation all these properties have to be taken into account. The figure below displays the entire structure (*Figure 4*).

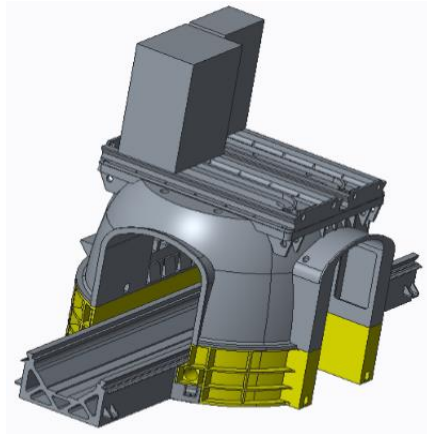
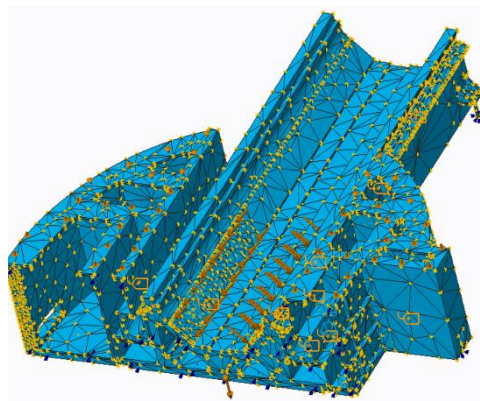

**Figure 4**

*The assembly model of the entire structure of the machine*

The wedge-like parts on the top of the central part of the structure symbolize the units for roughing and finishing machining operations and which are still in design phase, but their influence on the static stiffness cannot be ignored. One of our simu-

lations targeted the behaviour of the structure during the different stages of the installation and assembling process, when at a certain stage the entire structure is supported only by the pins on bottom of the structure, and when the filling material layer between the floor and the structure is not yet prepared. Among these simulations, one referred to the investigation of the deformation field of the structure, when the model is subjected to the gravitational force. The completed mechanical model, including the material properties, the kinematical and dynamical boundary conditions, and the FEM-meshing, is depicted by *Figure 5*.



**Figure 5**

*The structural model using the symmetrical features*

It is clearly seen, that only one half of the entire structure is included by the investigations. This enabled by the symmetry of the geometry and the boundary conditions, hence the number of the finite elements, thus the computational time and capacity is reduced significantly, while the accuracy of the computations can be increased. The refinement of the model above is achieved by adding the influence of the prestressed bolt-connections between the parts of the construction and, after the computations, the following displacement field is yielded (*Figure 6*).

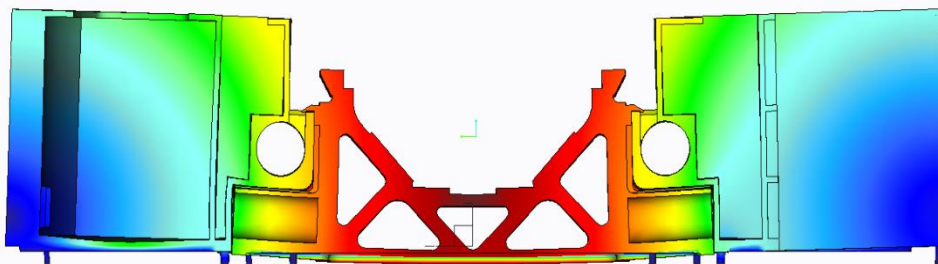

**Figure 6**

*The displacement field at a cross-section in deformed state*



The simulation mentioned above has given an evidence and supported the preconceptions of the design engineer i.e., some additional supporting pins are necessary to be placed on the bottom surface of the X-bed in order to compensate the mechanical stresses due to the large deflection of the construction hence, the risk of the fracture failure during the installation is reduced significantly.

As regards the static stiffness of the ram of the unit for the roughing machining operations, the need for similar structural simulations mentioned above have risen. The stroke of the ram is 800 mm hence, due to the loadings from the manufacturing process, it is subjected to bending loading which depends on the actual extension of the ram. The coloured chart below depicts the deformed displacement field at a certain extension of the ram (*Figure 7*). The ram includes and grabs the manufacturing tool and is displayed in red on the chart below.

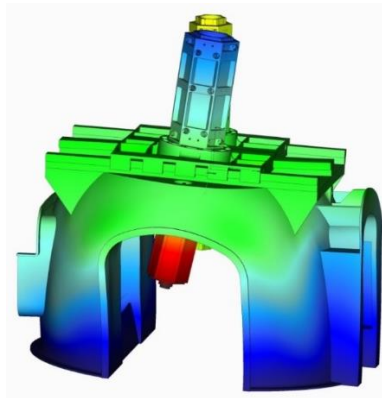

**Figure 7**

*The deflection of the ram at rough milling*

Each simulation conducted for investigating the bending loading of the ram at each extension, is included by one global sensitivity analysis, by which a chart is yielded displaying the deflection of the end of the ram (i.e., the assumed tool center point referred as TCP in the followings) versus the actual extension of the ram (*Figure 8*).

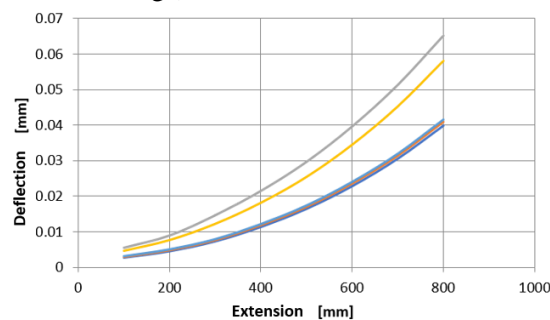

**Figure 8**

*Deflection of the TCP vs. the extension of the ram*

The curves of the chart above refer to such varieties of the ram, which have different cross-sections and guides i.e., rams with hexagonal or octagonal cross-sections and with rolling or sliding guides placed at various places and numbers have been investigated. The figure below depicts a housed ram with guides placed along the stroke and the number of the guiding elements at each cross-section (*Figure 9*).

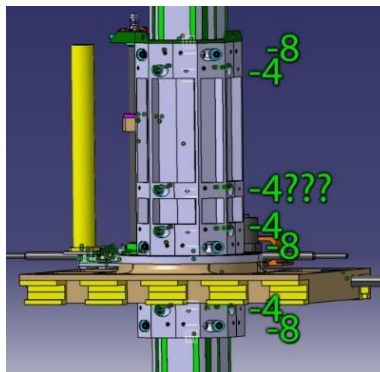
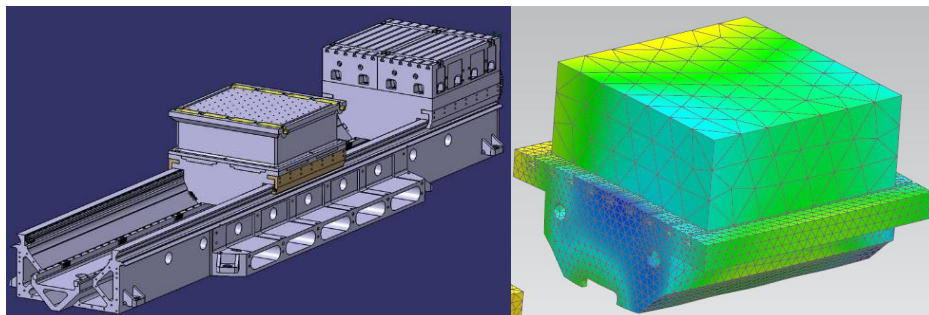

**Figure 9**

*The housed ram with indicating the guided cross-sections*

For the sake of the simplicity and an instant preliminary comparison, the applied loading are assumed to be static during the investigations. For further detailed simulations, dynamic loading cases were also applied for judging the dynamic stiffness properties.

Another investigation has been conducted on the structural properties of the X-bed and the X-lathe operating along the X-axis (*Figure 10 – left*). The result of the computations referring to the displacement field is displayed in *Figure 10 – on the right*. This latter simulation was to uncover the structural features (displacement and stress fields) of the X-lathe, which is subjected to the loadings from the roughing manufacturing operations and the gravitational force. These computations served as a basis for the optimization simulation of the static stiffness of the X-lathe.



**Figure 10**

*The 3D geometrical model – on the left, the structural analysis – on the right*

As a result of these numerical calculations, the geometrical shape of the structure was finalized, which enabled the manufacturing of the cast (*Figure 11*).



**Figure 11**

*The cast of the structure with optimized geometry*

## 5. SUMMARY

This paper summarizes the most important phenomena from the field of mechanical engineering, which rises frequently during the operation of a manufacturing device or a machine-tool. We pointed out that the overwhelming majority of these phenomena cannot be investigated by the means of the theoretical analysis properly, the establishment of the exact and closed-form solutions can be conducted only in minor cases. In these case the numerical methods of the mechanics or thermodynamics are preferred to the analytical ones. Among the numerical methods, the finite element method (FEM) is assumed to be the most frequently applied on the field of engineering. The efficiency of the FEM was demonstrated through the analysis of certain examples and we can claim that the method is a very comfortable procedure for enabling the investigation of the phenomena related with the operation of machine tools. This is particularly true for so called comparing studies, by which the directions of the design and development can be set up and the dead-end constructions can be avoided. The quality of the meshing however requires special attention, particularly when the problems related with contact analysis, where the accuracy and the optimal computational time is vital

## ACKNOWLEDGEMENT

The described article/presentation/study was carried out as part of the EFOP-3.6.1-16-2016-00011 *Younger and Renewing University – Innovative Knowledge City – institutional development of the University of Miskolc aiming at intelligent specialisation* project implemented in the framework of the Szechenyi 2020 program. The realization of this project is supported by the European Union, co-financed by the European Social Fund.

**REFERENCES**

- [1] Baráti A. (1988). *Szerszámgép vizsgálatok*. Budapest, Műszaki Könyvkiadó.
- [2] Faragó K. (1985). *Színhajtású szerszámgép főorsók nemlineáris rezgései*. Candidate dissertation, Miskolc.
- [3] Kollányi T. (2003). *Szjágak transzverzális lengései*. PhD dissertation, Miskolc.
- [4] Mekid, S. (2009). *Introduction to precision machine design and error assessment*. Boca Raton–London–New York, CRC Press Taylor&Francis Group.
- [5] Páczelt I. (1999). *Végeselem módszer a mérnöki gyakorlatban*. I. kötet, Miskolci Egyetemi Kiadó pp. 36–37.
- [6] Patkó Gy. (1998). *Dinamikai eredmények és alkalmazások a géptervezésben*. Habilitation booklet, Miskolc.
- [7] Patkó Gy. (1984). *Közelítő módszer nemlineáris rezgések vizsgálatára*. Candidate dissertation, Miskolc.